



股票简称：科林电气
股票代码：603050

KE-6710-V5 7kW

(32A)

V1.0





| | | |
|------|------------|--|
| | | |
| V1.0 | 2023-06-26 | |
| | | |
| | | |
| | | |
| | | |
| | | |



1

2 7KW

2.1

2.2

2.3

2.4

2.5

3

3.1

3.2 " "

4

5

6

7



1

2



林中心

3

4

1

W

7kV5ž5Ń P Ê'j•SžEç 5ž6€y ÓYà

í





2.2

GB/T 20234.1

1

GB/T 20234.2

2

2.3

1.0

2.4

220V± 15%

50± 1Hz

220V± 15%

50± 1Hz

32A

-25 +60

-25 +60

5% 95%

IP55

3.5kg

190*300*100(* *) mm

2.5

:

:

:
:
:
:

S2 : 3s 1
: 3s 2
CP : 3s 3
: 3s 4
: 1 1 3s
: 2 1 3s
: 3 1 3s
: 4 1 3s
: 3s 2
: 3s 3
, 0: 3s 4
: 1 1 3s
: 2



1

3s

3

2

3.1

IC

IC

A.

B.

3.2

"

"

"

"

"

"

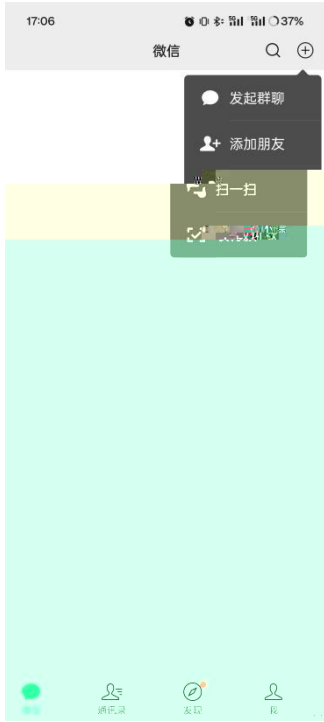

"

B

" 2 "

"

"

"

"

"

"

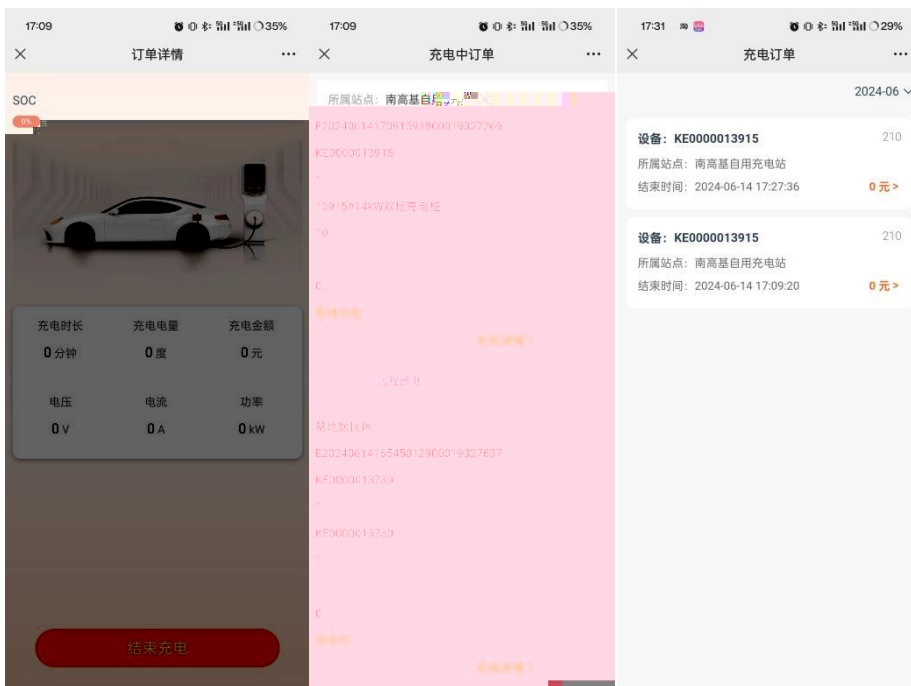
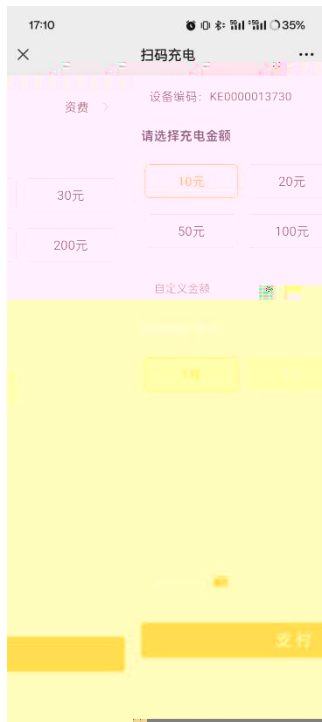

“ ”

" "

4

1 7kW 220V

2 () , ,
(RV5. 5- 4L)

8-10mm

()

,

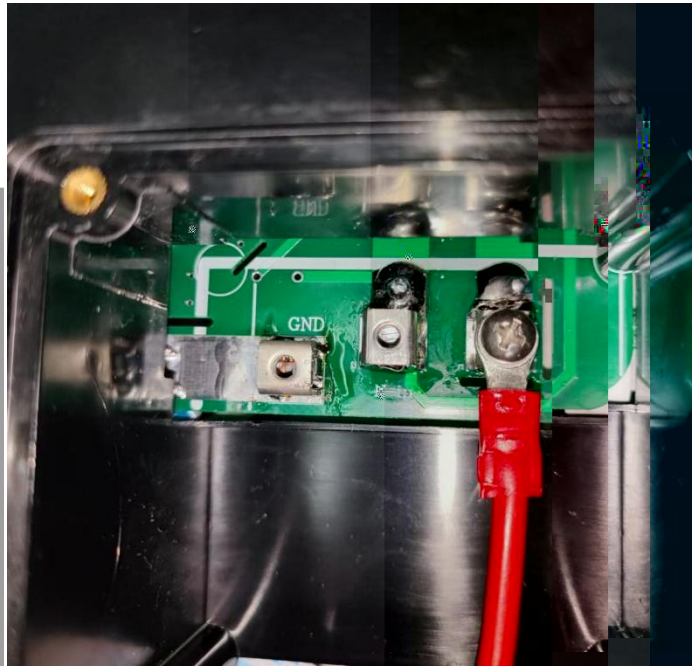
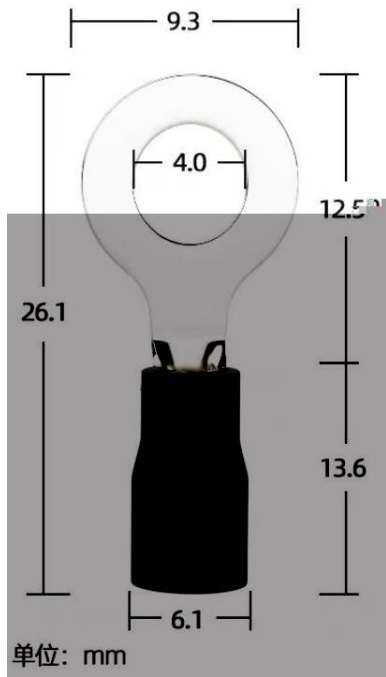

3

1

2

1

1

2

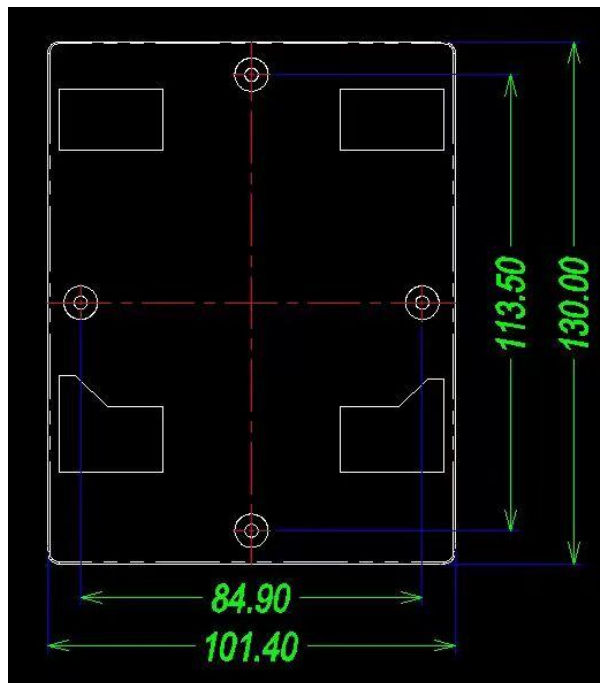

2

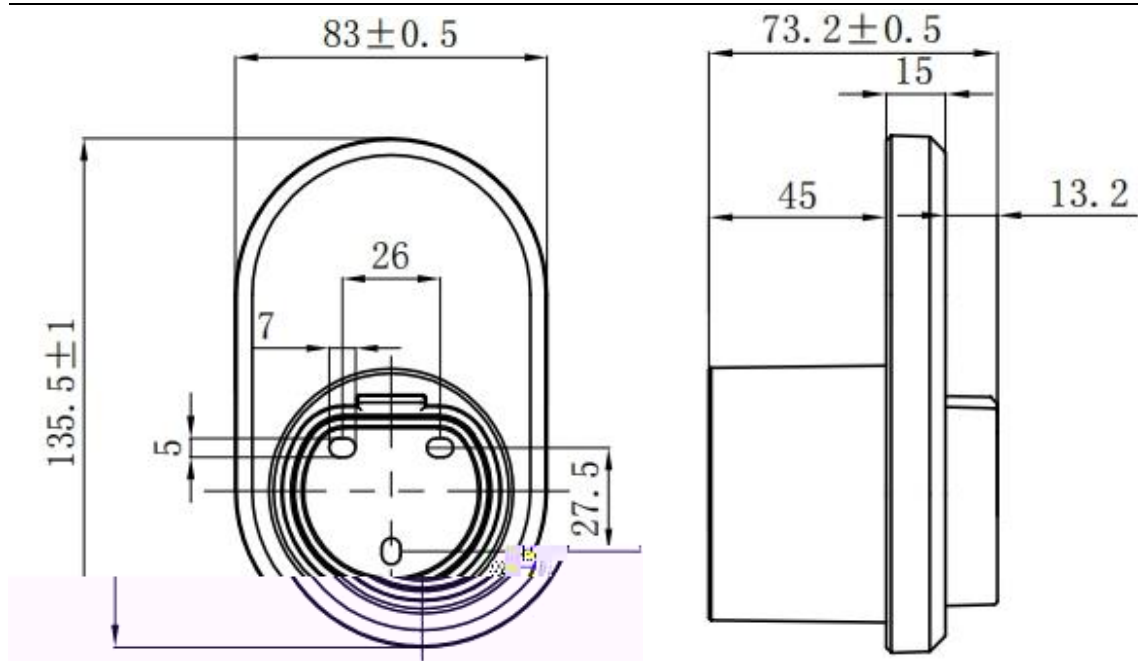

450*200*450

* *

M10*80

75*35mm

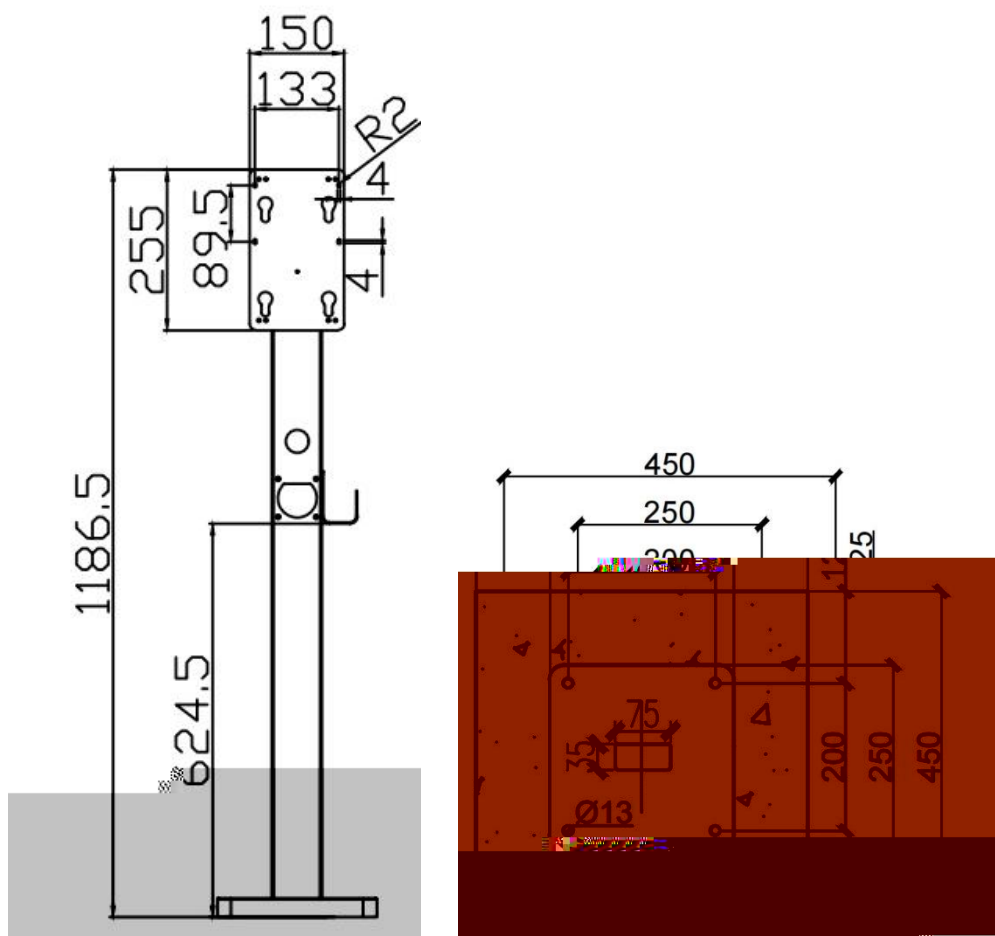

4

32A

63A

50A- - 30mA

ZR-YJV- 3*6

5

6

7



5

6

7

7.1

7.2

| | |
|--|--|
| | |
| | |
| | |

7.3

| | | | | |
|--|--|--|--|--|
| | | | | |
| | | | | |
| | | | | |
| | | | | |
| | | | | |

1 ()
/ 1

2 ()

3 /
1

4

1) ()

2)

3)

4)

5) $\frac{1}{2} \ln \frac{1}{3} + \ln \frac{1}{2} / e \quad FP @ \text{£}^- \cdot > | i^\circ \text{ } \text{ } \text{ } @$

8)

9)

10)

5

, ()

6

,

7

,

050222

0311-85231078

400-0311-128

0311-69099681